



洲光源
CHAULIGHT

产品规格书

SPECIFICATION

客户名称: _____

Customer Name

产品类型: 反射式光电开关

Product Name

产品型号: ZSOS-R2016B-08D-Z4

Part No.

<input type="checkbox"/> 技术参考 Technical Reference		<input type="checkbox"/> 样品 Sample		<input type="checkbox"/> 量产供货 Mass Product	
客户审核 (加盖公章) Client approval (Stamp)			洲光源审核 Chaulight approval		
核准 Approval	确认 Checked	核准 Approval	确认 Checked	制作 Edited	
<input type="checkbox"/> 接收 Qualified		<input type="checkbox"/> 不接收 Disqualified		日期 Date:	

联系电话(Tel): 0760-88504720

传真(Fax): 0760-88504721

地址(Add): 广东省中山市东升镇联胜南路 3 号洲光源科技园

No.3,Lian Sheng South Road ,Dong Sheng Town,Zhongshan City,Guang Dong Province.

本规格书仅用于双方交流用需经双方签订后方可生效,自签订后有效期为两年,期满后需以书面形式续签。最终解释权为洲光源所有。

This product specification is only used for technical communication.Only after the signature or seal, the specifications have the force of law.since the signing of the validity period of two years, after the expiration of the written renewal. The final interpretation right is owned by the CHAULIGHT.

广东洲光源红外半导体有限公司
Guangdong Chaulight Infrared Semiconductor Co.,Ltd.

ZSOS-R2016B-08D-Z4 由激光发射二极管和硅光晶体管组成，它们并排封装在黑色热塑性外壳中的汇聚光轴上。光电晶体管只接收来自 IR 的辐射。这是正常情况。但当物体在中间时，光电晶体管不能接收辐射。有关更多组件信息，请参阅 IR 和 PT。

The ZSOS-R2016B-08D-Z4 Composed of laser emitting diodes and silicon transistors, encased side-by-side on converging optical axis in a black thermoplastic housing. The phototransistor receives radiation from the IR only. This is the normal situation. But when an object is in between, phototransistor could not receives the radiation. For additional component information, please refer to IR and PT.

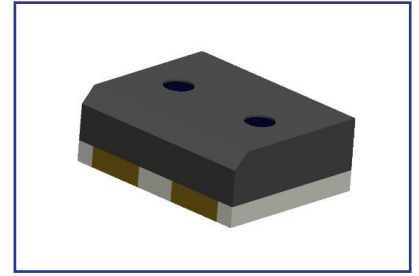

特性 Feature

- 可靠性高、辐射强度高、低电压驱动
High reliability、High radiant intensity、Low forward voltage、
- 感应速度快、感光度强
Fast response time、High photo sensitivity
- 截止感应波长 940nm
Cut-off visible wavelength $\lambda_p=940\text{nm}$
- 无铅材料、Rosh 认证
Pb.Free、RoHS compliant version

应用 Application

- 蓝牙耳机、非接触开关
TWS、Non-contact Switching
- 智能电子产品
Intelligent Electronic Products

最大额定值 Absolute Maximum Ratings

测试项目 Parameter (Ta=25°C)					
Optical Output Power	P _{OP}	5	6	—	mW
Threshold Current	I _{th}	—	1	2	mA
Operating Current	I _{op}	—	7	—	mA
Differential resistance	R _S	—	60	80	
Operating Voltage	V _{op}	1.8	2.1	2.4	V
Slope Efficiency	η _s	0.8	1	—	W/A
Power Conversion Efficiency	PCE	38	41	—	%
Wavelength	λ _{peak}	930	940	950	nm
Spectral Width (RMS)	Δλ	—	1	2.5	nm
Beam Full Divergence (D86)	φ	16	20	24	°
ESD tolerance, human body model	ESD	260			V
Optical Output Power	P _{OP}	5	6	—	mW
工作温度 Operating Temperature	T _{opr}		-25~+85	°C	
储存温度 Storage Temperature	T _{stg}		-40~+100	°C	
焊接温度 Lead Soldering Temperature* ³	T _{sol}		260	°C	

*1、在 25 摄氏度的环境中测试 below 25 Free Air Temperature

*2、脉宽少于等于 100us, 占空比 1% Pulse width ≤ 100μs, Duty cycle= 1%

*3、离胶体 2mm 以上焊接 5s 内 2mm form body for 5 seconds

光电特性 Electro-Optical Characteristics

电性参数 (温度=25°C) Parameter (Ta=25°C)		符号 Symbol	条件 Condition	最小值 Min.	典型值 Typ.	最大值 Max.	单位 Units
输入端 Input	正向电压 Forward Voltage	V_F	$I_F=20\text{mA}$	--	1.2	1.5	V
			$I_F=100\text{mA}^{*2}$	--	1.4	1.85	
			$I_F=1\text{A}^{*2}$	--	2.6	4.0	
	峰值波长 Peak Wavelength	λ_p	$I_F=20\text{mA}$	--	940	--	nm
	反向电流 Reverse Current	I_R	$V_R=5\text{V}$	--	--	10	μA
输出端 Output	暗电流 Dark Current	I_{CEO}	$E_e=0\text{mW/cm}^2$ $V_{CE}=20\text{V}$	--	--	30	μA
	集电极-发射极的工作电压 C-E Saturation Voltage	$V_{CE(SAT)}$	$I_C=2\text{mA}$ $E_e=1\text{mW/cm}^2$	--	--	0.4	mW/sr
转换特性 Transfer Characteristics	上升时间 Rise Time	t_r	$V_{CE}=5\text{V}$ $I_C=1\text{mA}$	--	15	--	μs
	下降时间 Fall Time	t_f	$R_L=1000\Omega$	--	15	--	
	光电流 Collector Current	$I_{C(ON)}$	$I_F=10\text{mA}$ $V_{CE}=5\text{V}$	0.18	1	--	mA

*2

、脉宽少于等于 100us, 占空比 1% Pulse width $\leq 100\mu\text{s}$, Duty cycle= 1%

产品尺寸 Package Dimension

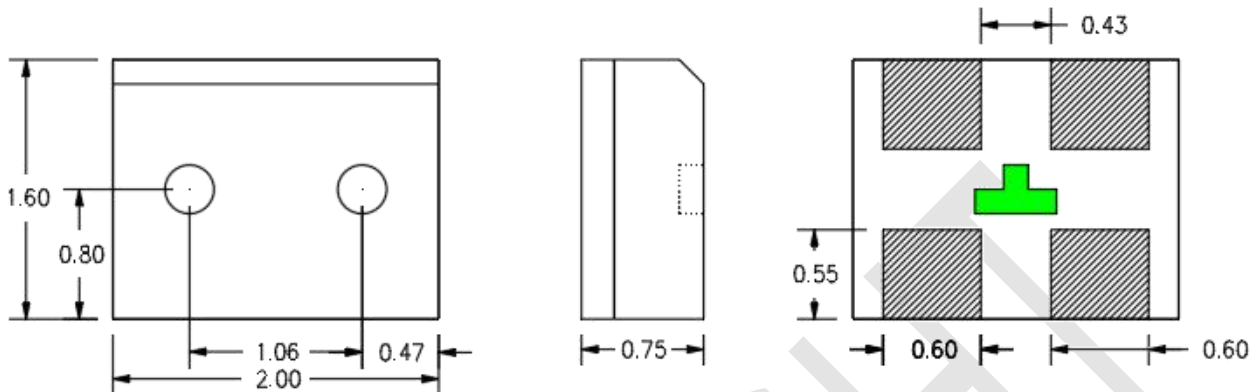

Tolerance: $\pm 0.02\text{mm}$.

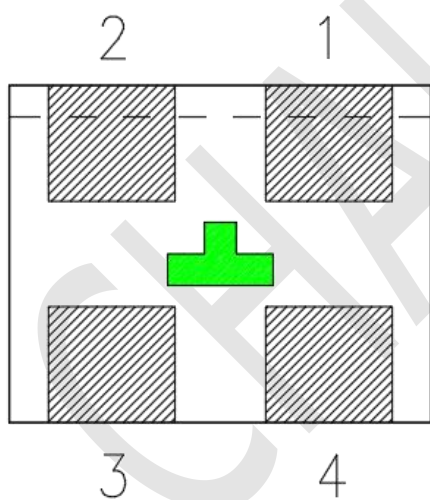

1:LD-
2:VCC
3:VOUT
4:LD+

备注 Notes:

--所有尺寸为毫米标识

All dimensions are in millimeters

--未标识尺寸正负公差为 0.3mm

Tolerances unless dimensions $\pm 0.3\text{mm}$

应用程序电路的工作顺序 Working sequence of application circuit

For example, 250us is used to work for 50ms (the average current is 30uA), and the timing is adjusted according to the actual application. Standby current 180nA

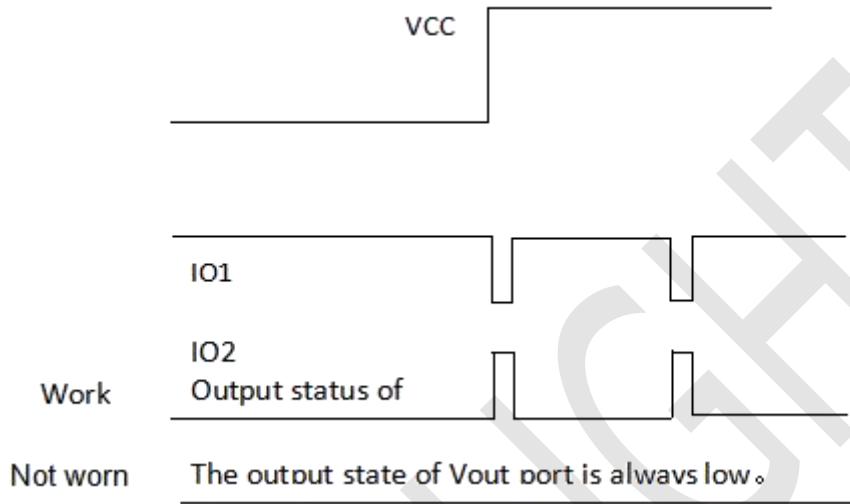

Typical application circuit:

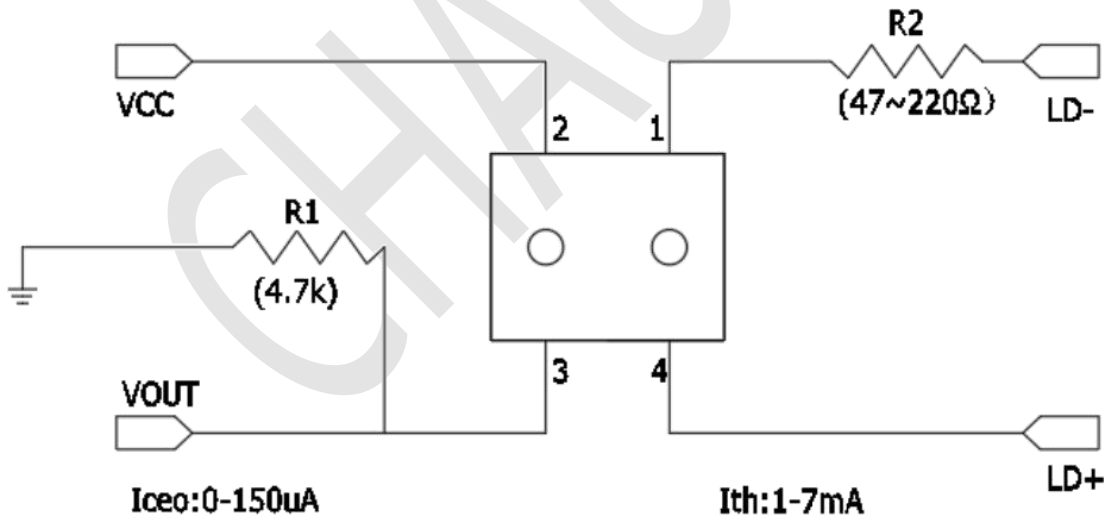

In this paper, the total system control circuit based on SoC Qualcomm QCC3046 was designed. (For reference only, please refer to the actual design)

Resistance design reference value

Resistance	Sensing distance	Comment
47Ω	≈6mm	The smaller the resistance value, the greater the induction distance. The greater the resistance, the smaller the induction distance.
67Ω	≈5mm	
87Ω	≈4mm	
120Ω	≈3mm	

Typical application circuit:

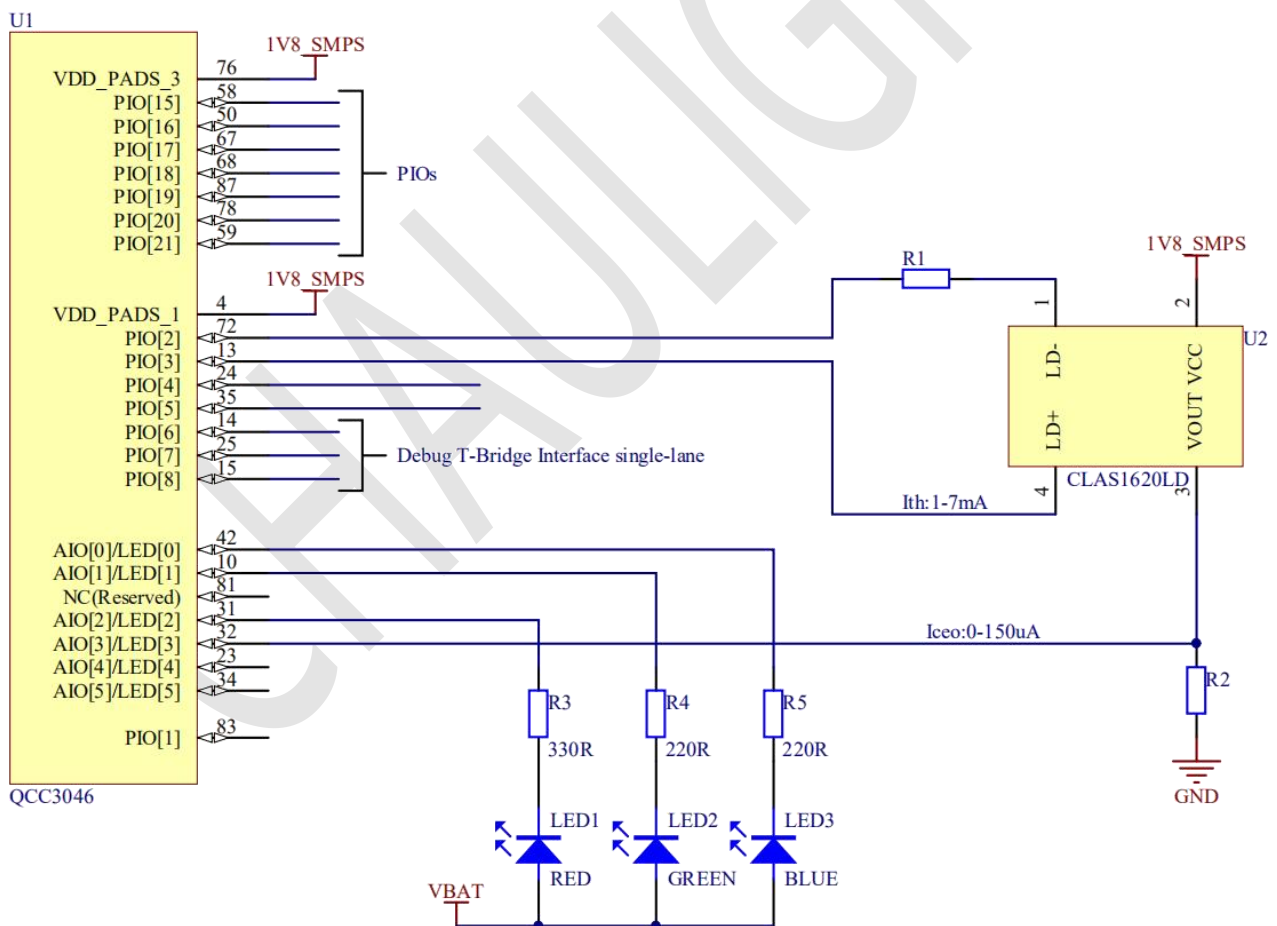

Structural design reference:

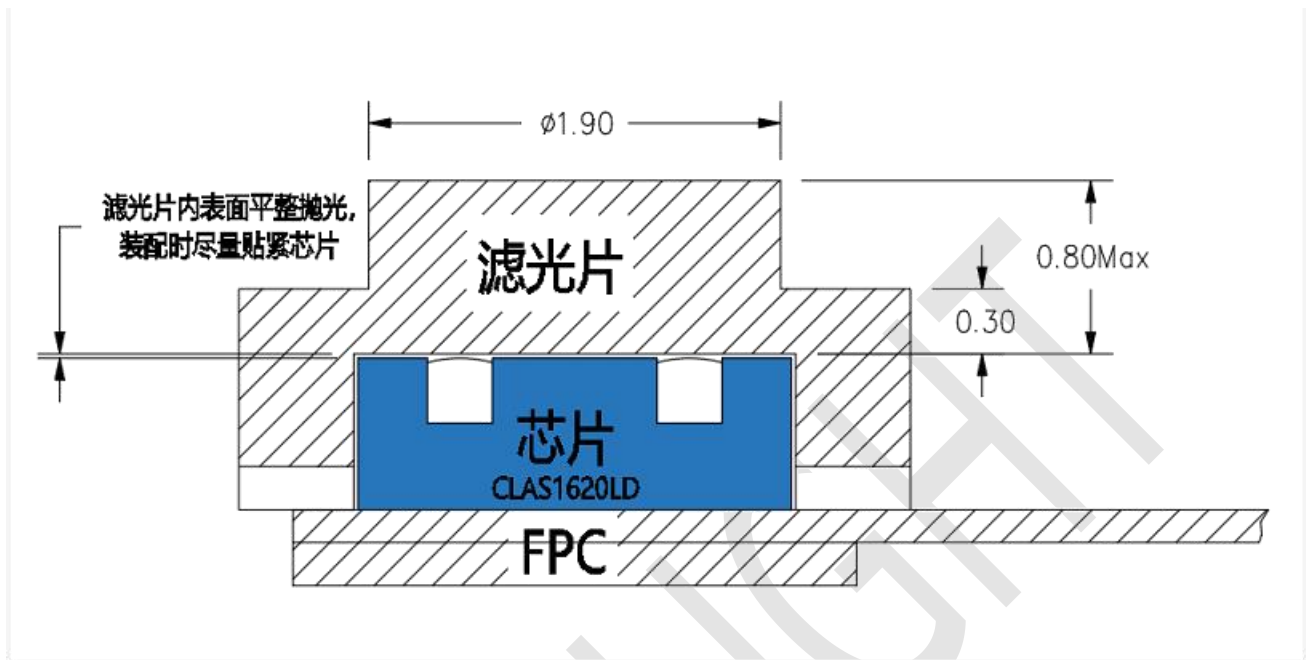

NO.	Name	Features	Comment
1	FPC	Connect sensor to PCBA.	
2	Photoelectric sensor	It is used to detect the non-electric quantity which directly causes the change of light quantity, such as light intensity, illumination, radiation temperature measurement, gas composition analysis, etc. Can also be other non-electric charges, such as part diameter, surface roughness, strain, displacement, vibration, etc., that can be converted into changes in the amount of light. Speed, acceleration, as well as the shape of the object, the recognition of the working state. Photoelectric sensor with non-contact, fast response. Therefore, it has been widely used in industrial automation devices and robots.	
3	Filter	Used to filter light beyond the wavelength of 940nm.	

●Tapping and packaging specifications (Units: mm)

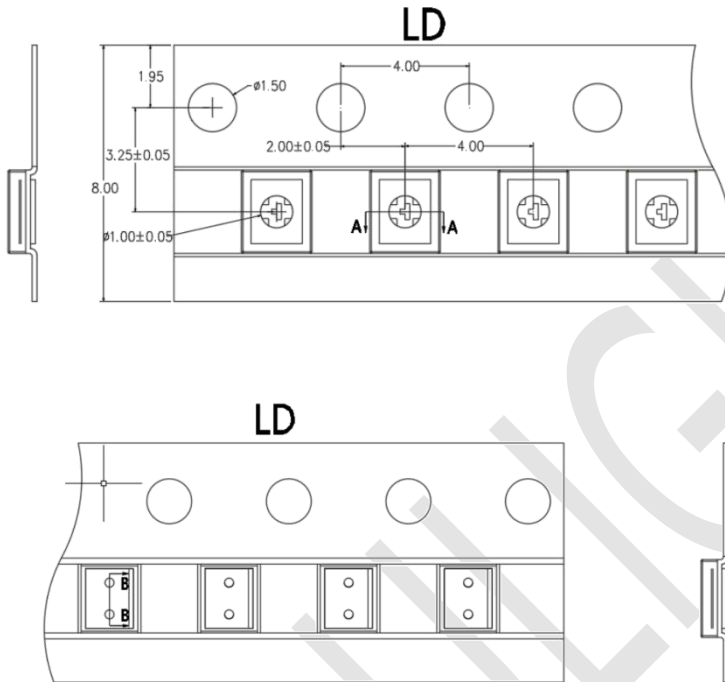

●Package Method:(Units: mm)

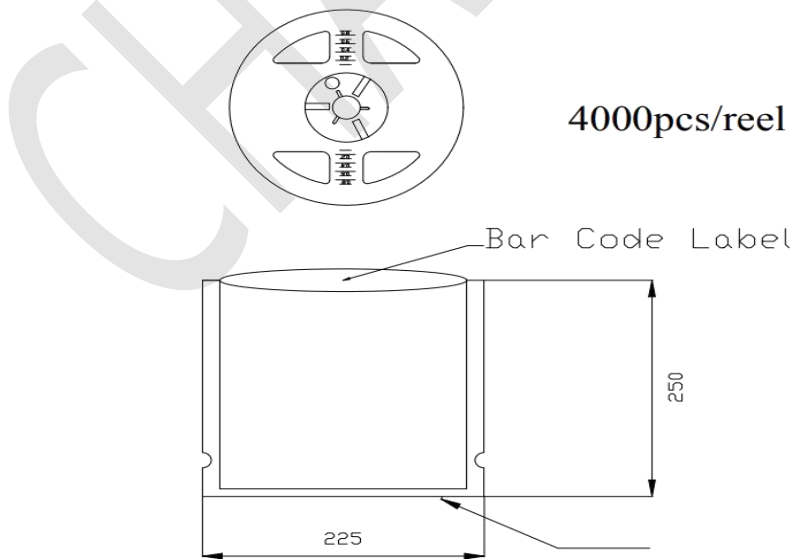

Parameter	Reference	Device
Average temperature gradient in preheating		2.5°C/sec
Soak time	t_{soak}	2 to 3 minutes
Time above 217°C (T_1)	t_1	Max 60 sec
Time above 230°C (T_2)	t_2	Max 50 sec
Time above $T_{peak} - 10^\circ\text{C}$ (T_3)	t_3	Max 10 sec
Peak temperature in reflow	T_{peak}	260°C
Temperature gradient in cooling		Max -5°C/sec

--焊接 Soldering

1、胶体不可侵入锡槽内.Epoxy non-invasive tin tank.

2、加热过程中不能对引脚施加压力。Pin pressure can not be applied during heating.

3、推荐焊接条件 260°C <5s 或 340°C <3s Recommended welding conditions 260°C <5 s or 340°C <3 s.

注：建议客户尽量使用较低的温度和较短的时间进行焊接；在符合以上推荐回流曲线条件下的死灯上 限为 500PPM. Note:Customers are advised to use lower temperature and shorter time for welding as far as possible; the upper limit of dead lamp under the condition of PPM. above recommended reflux curve is 500.

4、建议客户在经波峰焊后加装风扇，以利散热，需等 LED 冷却后（最好为室温后），再进行下一工序 加工。 Customers are advised to install fan after wave peak welding to facilitate heat dissipation, need to wait for LED cooling (preferably after room temperature) before the next process processing.

推荐回流焊曲线 Recommended Reflow Welding Curves

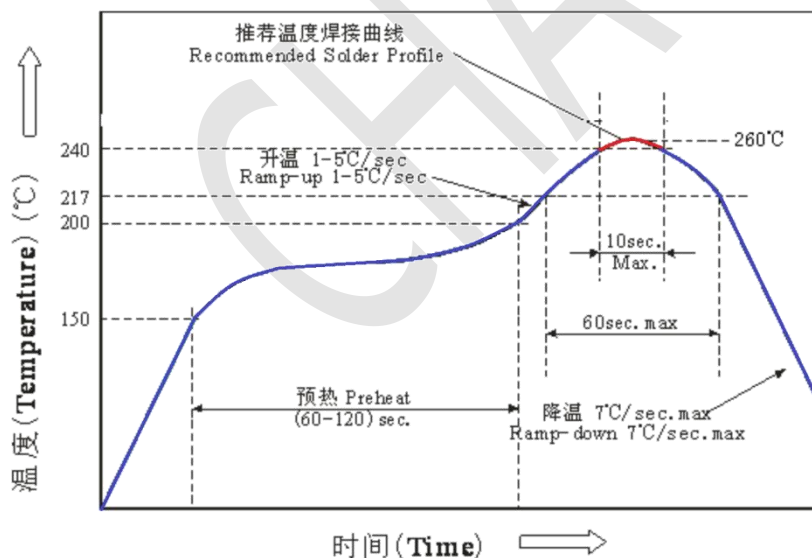

► 注意事项 Note

--其他 Other

- 1、以上规格可更改，恕不另行通知。 洲光源将为上述规格的材料变更保留权力 Above specification may be changed without notice. CHAU LIGHT will reserve authority on material change for above specification.
- 2、当使用此产品时，请观察这些规格表中概述的绝对最大额定值和使用说明。洲光源不承担任何损坏结果的责任从不符合绝对最大额定值的产品的使用和这些规格表中包含的说明 When using this product, please observe the absolute maximum ratings and the instruction for using outlined in these specification sheets. CHAU LIGHT assumes no responsibility for any damage resulting from use of the product which does not comply with the absolute maximum ratings and the instructions included in these specification sheets.
- 3、此规格书版权属广东洲光源红外半导体有限公司。未经允许不得转载或复印。These specification sheets include materials protected under copyright of CHAU LIGHT corporation. Please don't reproduce or cause anyone to reproduce them without CHAU LIGHT 's consent.

► 更改记录表 Engineering Change Notice-Record

版本 Edition	更改日期 Date	主要更改内容 Main Content	拟制 Prepared	确认 Checked
1.0	2021-1-12	新产品发布 New Production	黄瑞良	郝三强